

ALUMINUM CYLINDERS



MODEL:SSA-SERIES

Capacity: 20 - 100 Ton
 Stroke: 50 - 250 mm
 Spring Return, Single Acting
 Max. Working Pressure: 700 bar / 10,000 psi



FEATURES

- Half weight of the steel cylinders.
- Heavy duty spring for fast & full retraction.
- Large saddle surface for side load protection.
- Carrying handles are equipped for all models.
- Hard-Anodized coating reduces wear & corrosion.
- Rod wiper protects inner rod from dirt.
- Stop rings for piston blow-out protection.

Base Plate Mounting Holes Dimensions(mm)

Model No./ Capacity (ton)	Bolt Circle U (mm)	Thread V (mm)	Thread Depth Z (mm)
SSA-20	70	M6x1.0	20
SSA-30	80	M6x1.0	10
SSA-50	110	M6x1.0	10
SSA-100	160	M6x1.0	10

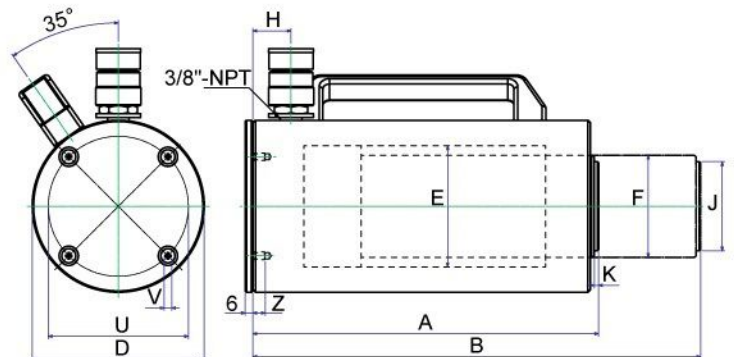

SPECIFICATIONS

Model No.	Capacity (ton)	Stroke (mm)	Cylinder Effective Area (cm ²)	Oil Capacity (cm ³)	Collapsed Height A (mm)	Extended Height B (mm)	Outside Diameter D (mm)	Cylinder Bore Diam E (mm)	Plunger Diameter F (mm)	Base to Advance Port H (mm)	Saddle Diameter J (mm)	Saddle Protrusion from Plunger K (mm)	Weight (kgs)
SSA202	20	50	33.2	166	168	218	92	62	55	25	40	3	4.3
SSA204		100	33.2	332	218	318	92	62	55	25	40	3	5.0
SSA206		150	33.2	498	268	418	92	62	55	25	40	3	5.7
SSA208	30	200	33.2	664	318	518	92	62	55	25	40	3	6.5
SSA302		50	44.2	221	175	225	110	75	60	25	40	3	6.0
SSA304		100	44.2	442	225	325	110	75	60	25	40	3	6.9
SSA306	50	150	44.2	663	275	425	110	75	60	25	40	3	7.9
SSA308		200	44.2	884	325	525	110	75	60	25	40	3	8.8
SSA502		50	70.9	354.5	171	221	135	95	80	30	70	6	7.7
SSA504	100	100	70.9	709	221	321	135	95	80	30	70	6	9.1
SSA506		150	70.9	1063.5	271	421	135	95	80	30	70	6	11.7
SSA508		200	70.9	1418	321	521	135	95	80	30	70	6	13.5
SSA5010	100	250	70.9	1772.5	371	621	135	95	80	30	70	6	16.4
SSA1002		50	143	715	185	235	200	135	105	45	70	6	17.2
SSA1004		100	143	1430	235	335	200	135	105	45	70	6	21.0
SSA1006	100	150	143	2145	285	435	200	135	105	45	70	6	25.1
SSA1008		200	143	2860	335	535	200	135	105	45	70	6	28.5
SSA10010		250	143	3575	385	635	200	135	105	45	70	6	30.7